

SNAP-N-SEAL® "F" MALE ENVIRONMENTALLY SEALED CONNECTORS SNS59, SNS59HEC, SNS59QS, SNS6, SNS6QS

Pat. No. 4,902,246

1. Slide connector assembly over cable as shown. (When using Messengered/Siamese cable: Rib must be removed flush with cable jacket before connector installation, this step will insure proper installation and sealing).
2. Prepare cable using LRC #CST596 or #IT1000 tool as follows:

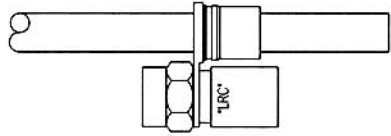

Cut the cable end off square before starting the prep.

(A) IT1000 tool: depress slide, then insert the cable up to cable stop. Grip cable close to tool and rotate tool approx. 1 to 3 full turns or until tool moves freely. Pull tool off cable, removing jacket prep and dielectric from center conductor.

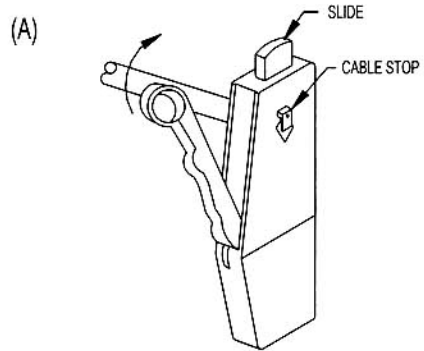

(B) CST596 tool: open tool by squeezing the handles, then insert the cable up to the cable stop. Grip cable close to tool and rotate tool approx. 8 to 12 full turns or until tool moves freely. Pull tool off cable, removing jacket prep and dielectric from center conductor.

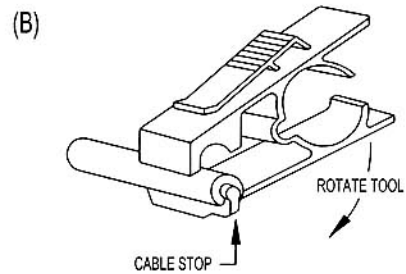

3. Cable end should be prepared as shown.
4. If using single braid cables, fold the braid over the jacket. If using double braid cables, fold the outer braid over the jacket. Score and remove foil (if applicable). Fold the inner braid over the jacket.

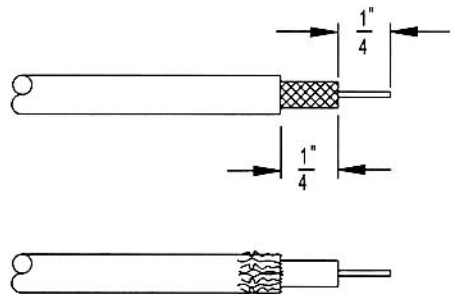

SNAP-N-SEAL® "F" MALE ENVIRONMENTALLY SEALED CONNECTORS SNS59, SNS59HEC, SNS59QS, SNS6, SNS6QS

Pat. No. 4,902,246

5. Twist connector to remove from plastic sleeve. (plastic ring may stay attached between connector collar and nut).

Place connector over cable end until cable dielectric is flush with end of post. Push plastic sleeve into connector.

6. Finish the connector to cable installation using LRC #SNSUTL or #IT1000 installation tool.

(A) Using IT1000 tool: place connector assembly inside tool as shown. Squeeze handle until the plastic sleeve snaps into the connector.

The plastic sleeve is in proper position when the connector is compressed to the indicator line scribed on the tool. A white indicator will also be visible thru the tool "sight hole".

(B) Using SNSUTL tool: align top of tool with the connector "U Groove", and push the connector and cable into the tool as shown. The cable should be held in place by the bottom of the tool, and the plastic sleeve should be seated into the "Clip Pocket".

Squeeze the handles together until the plastic sleeve snaps into place.

Seal the connector to the port using LRC's Nut Seal or Thread Protectors:

(A) Nut Seal: Thread nut seal all the way onto the F port with the O-ring facing out (minimum port length of .281 is required). Thread connector onto the port. Wrench tighten connector 25 to 30 in lbs. torque. When connector is tight, screw the nut seal back against the connector. Tighten nut seal 25 to 30 in lbs.

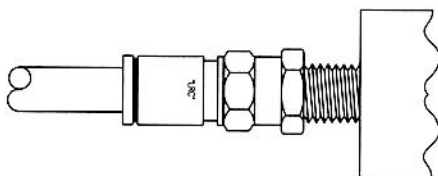
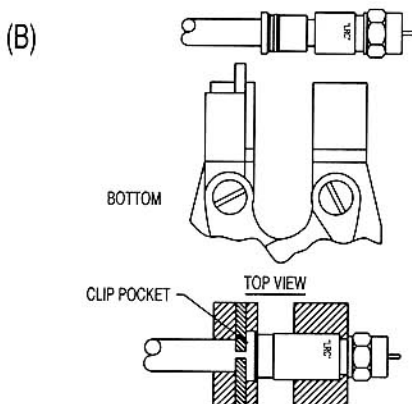
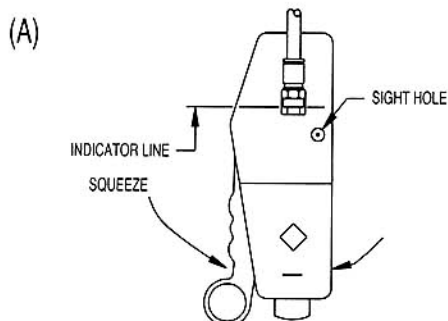
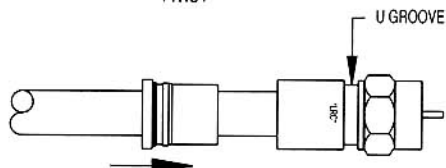
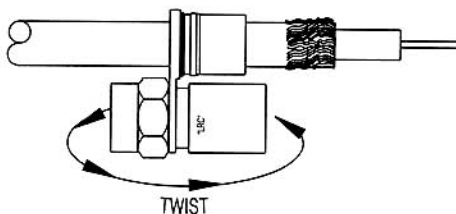

CONTINUED ON NEXT PAGE

SNAP-N-SEAL® "F" MALE ENVIRONMENTALLY SEALED CONNECTORS SNS59, SNS59HEC, SNS59QS, SNS6, SNS6QS

Pat. No. 4,902,246

(B) Thread Protectors:

Using the TP Chart, determine which thread protector should be used for your port length.

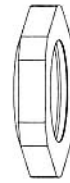

TP CHART

LRC PART #	MIN. PORT LENGTH	MAX. PORT LENGTH	FIG.#
TP275	.275	.335	1
TP450	.450	.510	2

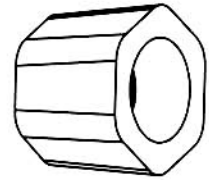

Push the larger diameter end, (see Fig. 1 or 2), over the F interface until seated against the interface surface (see Fig. 3).

- Thread SNS connector onto the port and wrench tighten 25 to 30 in lb. The end of the F connector nut should push against the end of the thread protector to ensure proper sealing.

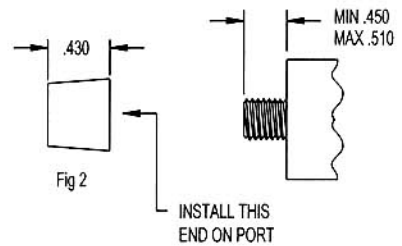
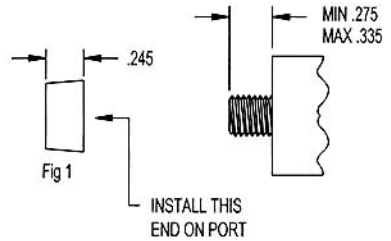

COLOR CODE CHART

PART NUMBER	O-RING COLOR
SNS59	Orange
SNS59QS	Green
SNS59HEC	White
SNS6	Blue
SNS6QS	Violet

