

Big-Grip Dead-end

NOMENCLATURE

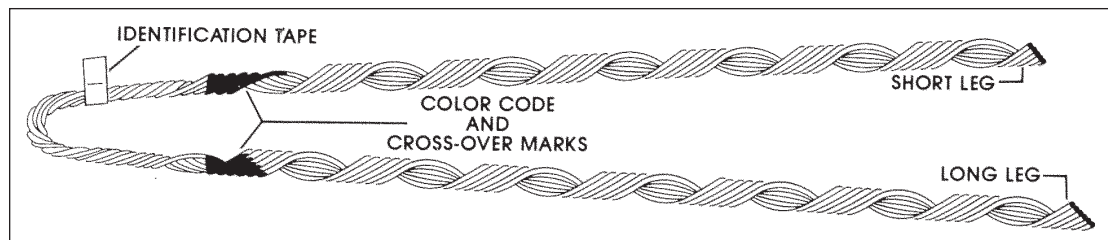

CROSS-OVER MARKS: Indicate starting point for application.

COLOR CODE AND LENGTH: Assist in identifying strand size, corresponding to tabular information appearing on catalog pages.

Identification Tape: Shows catalog number, nominal sizes.

Short Leg-Long Leg: Identifies rods belonging to each leg, after application. During application, the short leg should be applied first.

GENERAL INFORMATION

Big-Grip Dead-ends are designed for use on Transmission, Antenna, Communications, and other types of guyed structures that require use of large guy strand.

RATED HOLDING STRENGTH (RHS): Big-Grip Dead-ends are designed to develop the maximum loads published on the catalog pages only for those specific strands listed.

Test data available upon request.
Reference: TR-634-E

MATERIAL SELECTION: Big-Grip Dead-ends are made from material that is compatible with the strand they are designed to be used with **except where noted otherwise.**

This product is intended for a single (one-time) use and for the specified application, although it may be reapplied twice for retensioning within 90 days of initial installation. **CAUTION: DO NOT MODIFY OR REUSE THIS PRODUCT AFTER 90 DAYS UNDER ANY CIRCUMSTANCES.**

INSTALLATION GUIDELINES

STRAND COMPATIBILITY: Big-Grip Dead-ends should be used only on the size and strand for which they are designed. They must have the same lay as the strand to which they are applied.

When ordering Big-Grip Dead-ends, make sure to specify the strand on which it is to be used and the strand lay.

When using types of strand and/or sizes of strand not mentioned in these catalog pages, consult PLP for compatible Big-Grip Dead-end designs.

During installation and at all times, care should be taken to avoid gouging or damaging the corrosion preventive material of either the Big-Grip Dead-end or the strand.

Big-Grip Dead-ends must not be used as tools: that is, come-alongs, pulling-in grips, etc.

Normally tools are not required to install Big-Grip Dead-ends, however, a screwdriver may be used to split the legs into subsets. When splitting the legs, do not make more than two subsets per leg.

For hardware and hardware dimensions to be used in conjunction with Big-Grip Dead-ends, refer to Table 1 on the next page.

Big-Grip Dead-ends should not be used on hardware that allows the strand to rotate or spin about its axis uncontrolled. Adjustable hardware, such as a turnbuckle, may be used as long as rotational movement of the strand is restricted. Consult PLP[®] for additional information concerning adjustable hardware that can be used with Big-Grip Dead-ends.

Hardware used in conjunction with Big-Grip Dead-ends should have smooth contours, ample groove clearances, acceptable diameters and sufficient strength to minimize abrasion and fatigue of the loop area.

HARDWARE: Table 1, Figures 1-6 illustrate some of the possible hardware and the dimensions that may be used with Big-Grip dead-ends:

- (A) Figure 1 and Table 1 illustrate minimum and maximum acceptable seat diameters to which the Big-Grip Dead-end can be applied.
- (B) Figure 2 and Table 1 illustrate seat diameters and minimum groove diameters.
- (C) Figure 3 and Table 1 illustrate minimum hardware hole diameters.



Big-Grip Dead-end

THIMBLE RECOMMENDATIONS

- (A) Only heavy-duty type wire rope thimbles or solid Hawser type thimbles are recommended for use with Big-Grip Dead-ends. (Refer to Figures 4, 5, and 6)
- (B) Heavy-duty type wire rope thimbles can collapse when guy tensions are high. In order to support and protect the loop area of the Big-Grip Dead-end, special precautions are necessary.
- (C) In order to prevent collapse of the thimble, either a Hawser type thimble (Figure 4), a large pin inside the thimble (Figure 5), or a smaller pin (such as a shackle pin) plus double extra strong weight pipe or equivalent (Figure 6) is

necessary. Double extra strong weight pipe, which has increased wall thickness and strength over schedule 160 pipe, does not have a schedule number but information can be obtained from a pipe supplier. Thimble strengths and dimensions can be obtained from a thimble supplier.

PLP suggests guy tensions be maintained at a minimum of approximately 10% of the Strand's Rated Breaking Strength (RBS).

When in doubt about installations, hardware, or applications, contact your PLP representative.

Table 1 - BIG-GRIP Dead-end and Hardware Accessories Dimensions (All Dimensions In Inches)										Double Extra Strong Weight Pipe Fig. 6		
(All Dimensions in Inches)												
Dead-end Diameter Range	Nominal Strand Sizes	Fig. 1 & 2 Seat Dimensions		Fig. 2 Minimum Groove Diameter	Fig. 3 Minimum Hardware Hole Diameter*	Heavy Duty Thimble Size	Fig. 4 & 5 Pin Diameters		Nominal Size	O.D.	I.D.	
		Min	Max				Min	Max				
.174 -.203	3/16	1	(2-1/2) 1-3/4	1/4	3/8	7/16 - 3/8	5/8	1	3/4	1.050	.614	
.204 -.230	7/32	1-1/8	(2-1/2) 1-3/4	5/16	3/8	7/16 - 3/8	5/8	1	3/4	1.050	.614	
.231 -.259	1/4	1-1/8	(2-1/2) 1-3/4	5/16	7/16	1/2	1	1-3/8	1	1.315	.815	
.260 -.291	9/32	1-1/8	(2-1/2) 1-3/4	3/8	1/2	1/2	1	1-3/8	1	1.315	.815	
.292-.336	5/16	1-1/4	(2-1/2) 1-3/4	3/8	9/16	1/2	1	1-3/8	1	1.315	.815	
.337-.394	3/8	1-3/8	(2-1/2) 1-3/4	7/16	5/8	1/2	1	1-3/8	1	1.315	.815	
.395-.474	7/16	1-3/8	(2-1/2) 2-3/8	1/2	11/16	1/2	1	1-3/8	1	1.315	.815	
.475-.515	1/2	1-3/8	2-3/8	9/16	3/4	5/8	1	1-5/8	1-1/4	1.66	.896	
.516-.570	9/16	1-1/2	2-5/8	5/8	15/16	5/8	1-1/8	1-5/8	1-1/4	1.66	.896	
.571-.635	5/8	2	2-5/8	3/4	1	3/4	1-1/2	1-7/8	1-1/4	1.66	.896	
.636-.772	3/4	2-1/2	3-1/8	7/8	1-3/16	7/8	1-7/8	2-1/8	1-1/2	1.9	1.1	
.773-.868		2-1/2	3-5/8	1	1-3/8	1	2	2-3/8	2	2.375	1.503	
.869-1.024	7/8 or 1	3	4-1/8	1	1-3/8	1-1/8 - 1-1/4	2-3/8	2-3/4	2	2.375	1.503	
1.025-1.27		3-1/2	5-1/8	1-3/8	1-3/4	1-1/4 - 1-3/8	2-3/4	3-1/4	2-1/2	2.875	1.771	
1.30		4	5-1/8	1-3/8	1-15/16	1-3/8 - 1-1/2	2-7/8	3-3/8	2-1/2	2.875	1.771	

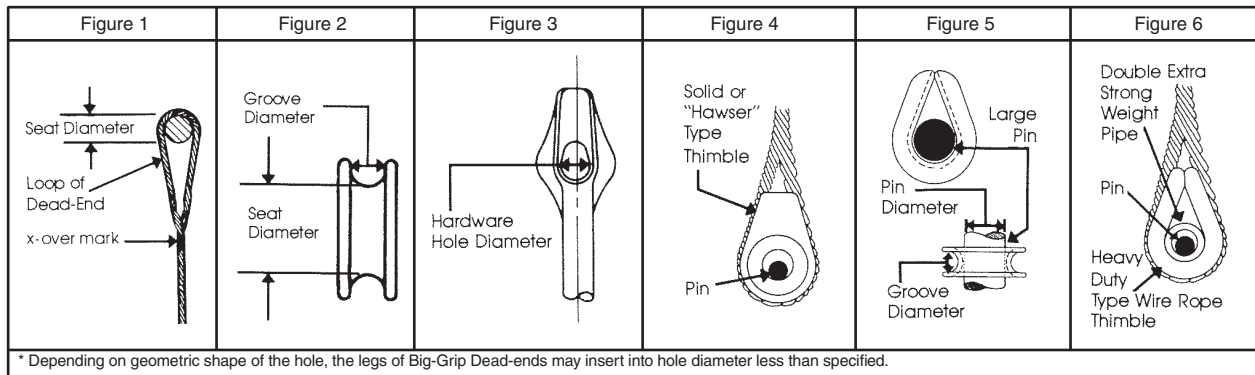

* Depending on geometric shape of the hole, the legs of Big-Grip Dead-ends may insert into hole diameter less than specified.

Big-Grip Dead-end

Articulated Hardware Recommended for Use with Big-Grip Dead-ends

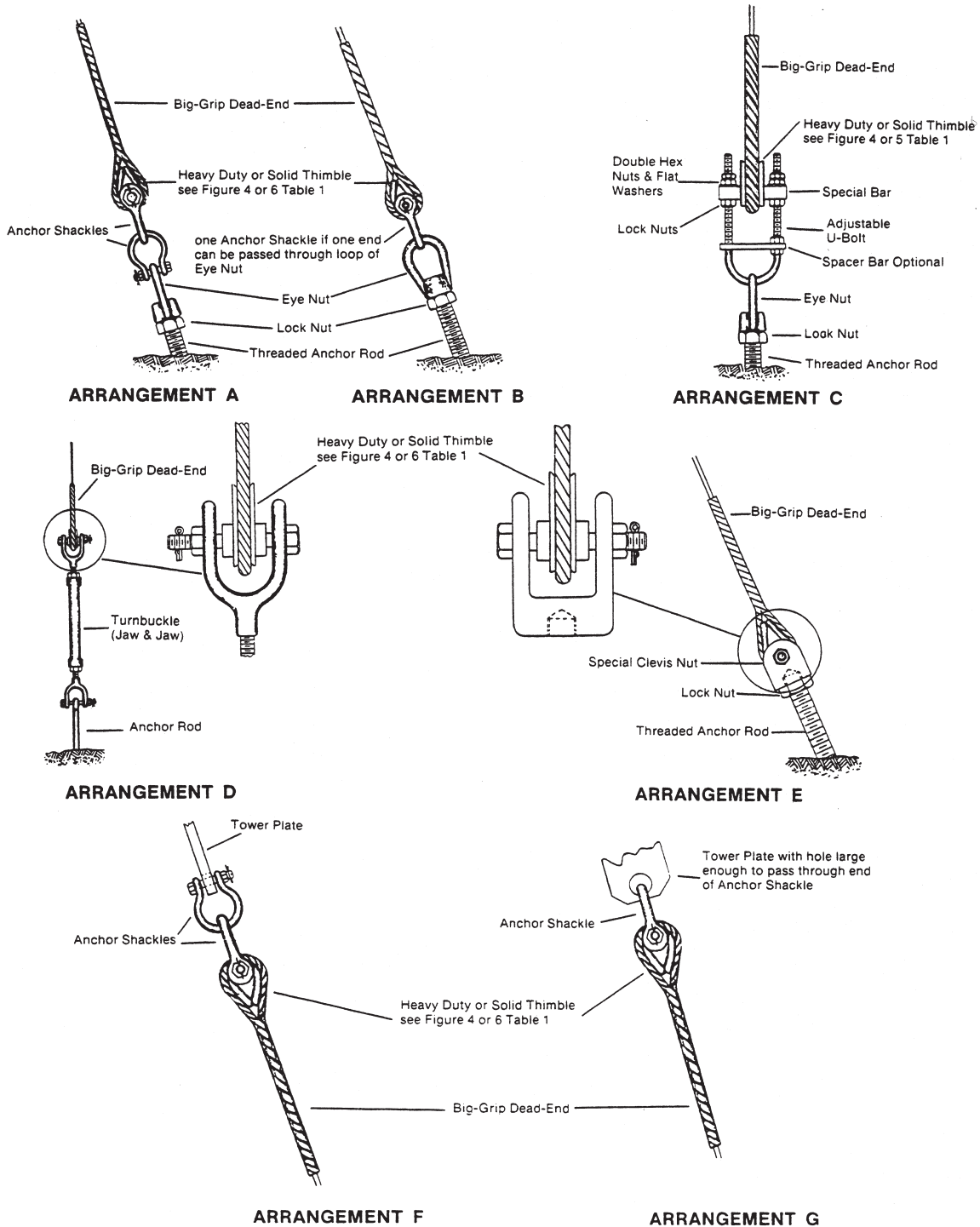



Big-Grip Dead-end

GALVANIZED STRAND

**For use on: Extra High Strength
Siemens Martin High Strength
Utilities Grade**

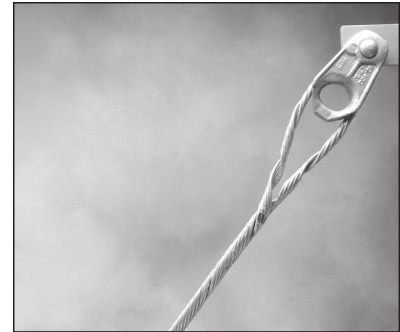

Catalog Number	Size (in)	Strand Construction	Actual Diameter (in)	BG Per Carton (Units)	BG Per Carton (wt/lbs)	Approx. Length (in)	Color Code	Rated Holding Strength (lbs)	Percent of Strands Rated Breaking Strength
BG-2140	1/8	7W	.123	100	11	14	Blue	1,830	(100%)
BG-2142	3/16	7W	.186	100	33	23	Red	3,990	(100%)
BG-2144	1/4	3W 7W	.259 .240	50	25	27	Yellow	6,650	(100%)
BG-2145	9/32	7W	.279	50	29	30	Blue	8,950	(100%)
BG-2146	5/16	3W 7W	.312 .312	50	41	33	Black	11,200	(100%)
BG-2147	3/8	3W 7W	.356 .360	25	33	37	Orange	15,400	(100%)
BG-2148	7/16	7W	.435	25	47	40	Green	20,800	(100%)
BG-2115	1/2	7W or 19W	.495 or .500	20	63	49	Blue	26,900	(100%)
BG-2116	9/16	7W or 19W	.564 or .565	10	48	55	Yellow	35,000	(100%)
BG-2111	5/8	7W or 19W	.621 or . 625	10	65	64	Black	7W 42,400 19W 40,200	(100%) (100%)
BG-1112	3/4	19W	.750	5	54	76	Orange	58,300	(100%)
BG-1113	7/8	19W	.885	5	76	90	Green	79,700	(100%)
BG-1114	1	19W or 37W	1.000 or 1.001	3	76	125	Blue	19W 104,500 37W 92,430	(100%) (90%)+

Left-hand lay is standard.

+ Down-Rated for 37 stranding (1994)

EXPLANATORY NOTES:

- (1) For strand sizes smaller than 1/2", refer to the GUY-GRIP® Dead-end.
- (2) Reference Table 1 earlier in this section for acceptable fitting dimensions.
- (3) Cabled loop design is furnished as standard for all sizes.
- (4) Rated Holding Strengths (RHS) of the Big-Grip Dead-ends are listed for each strand and are expressed as a percent of the strand's Rated Breaking Strength (RBS).
- (5) C-Coat galvanized steel is standard for all Big-Grip Dead-ends unless otherwise stated.
- (6) B-Coat galvanized steel is used for the Big-Grip Dead-ends used on 3/4", 7/8", and 1" strand.
- (7) The Aluminum Clad Steel version of the 7/8" and 1" Big-Grip are still available as catalog numbers BGMS7023 (7/8") and BGMS7047 (1").
- (8) Consult PLP for sizes and stranding not shown.

Big-Grip Dead-end

For use on: Aluminum Clad Steel Strand

Catalog Number	Strand Diameter Ranges (Inches)		Nominal Strand Size	BG Per Carton		Approx. Length (Inches)	Color Code	Rated Holding Strength (lbs)	(Percent of Strand's Rated Breaking Strength)
	Min	Max		Units	Wt/lbs				
BG-4202	.174	.181	3 # 12	100	22	19	Orange	2,850	(100%)
BG-4208	.219	.230	4M 3 # 10	50	21	22	Green	4,532	(100%)
BG-4210	.237	.247	7 # 12 6M	50	22	24	Yellow	6,000	(100%)
BG-4213	.270	.280	3 # 8 8M	50	24	27	Blue	8,000	(100%)
BG-4216	.303	.313	3 # 7 10M 5/16 7 # 10	50	32	29	Black	10,000	(100%)
BG-4220	.343	.355	3 # 12.5M 11/32 7 # 9	50	45	32	Yellow	12,500	(100%)
BG-4221	.350	.364	14M	50	60	35	Blue	14,000	(100%)
BG-4223	.380	.394	3 # 5 3/8 7 # 8 16M	50	62	36	Orange	16,000	(100%)
BG-4225	.410	.426	18M	25	43	39	Black	18,000	(100%)
BG-4226	.427	.442	7/16 7 # 7	25	44	40	Green	19,060	(100%)
BG-4227	.443	.459	20M	25	57	41	Yellow	20,000	(100%)
BG-4168	.475	.494	7 # 6	25	60	42	Blue	22,730	(100%)
BG-4169	.495	.515	19 # 10	25	62	44	Green	27,190	(100%)
BG-4170	.516	.536	25M	20	66	47	Red	25,000	(100%)
BG-4171	.537	.555	7 # 5	20	67	48	Yellow	27,030	(100%)
BG-4172	.556	.570	-	15	68	49	Blue	33,330	
BG-4173	.571	.591	19 # 9	20	68	50	Orange	34,290	(100%)
BG-4174	.592	.612	-	16	50	50	Green	34,450	
BG-4175	.613	.635	-	10	49	54	Yellow	45,000	
BG-4176	.636	.661	19 # 8	10	50	56	Black	43,240	(100%)
BG-4177	.662	.686	19 x .1363"	10	66	59	Blue	47,400	(100%)
BG-4178	.687	.712	-	10	68	61	Red	54,200	
BG-4179	.713	.741	19 # 7 37 # 10	10	70	63	Black	51,730 50,300	(100%) (95%)+
BG-4180	.742	.772	19 x .1499"	5	41	71	Yellow	54,300	(100%)
The Following Products Are For The Specific Cables Listed.									
Actual Diameters									
BG-4181	.792		19 x .1584"	5	50	80	Blue	59,000	
BG-4183	.801, .810, .827		37 # 9 19 # 6 19 x .1660"	5	69	84	Green	63,430 61,700 63,000	(95%)+ (100%) (100%)
BG-4185	.849, .850, .866		37 x .121" 19 x .170" 19 x .173" 37 x .123"	5	68	87	Black	71,250 66,000 68,500 74,100	(95%)+ (100%) (100%) (95%)+
BG-4186	.899		37 # 8	5	76	91	Yellow	80,000	(95%)+
BG-4187	.910 .934		19 # 5 19 x .1868"	5	78	93	Blue	73,350 75,000	(100%) (100%)
BG-4188	.981		37 x .1404"	4	52	95	Red	90,250	(95%)+
BG-4189	1.01		37 # 7	4	85	108	Green	90,600	(90%)+
BG-4190	1.10		37 x .1571"	3	84	117	Black	101,700	(90%)+
BG-4191	1.134		37 # 6	3	86	120	Yellow	108,200	(89%)
BG-4192	1.27		37 # 5	2	82	151	Red	127,000	(89%)

Left-hand lay is standard..

+ Down-Rated for 37 stranding (1994)

EXPLANATORY NOTES:

- (1) For strand sizes smaller than 7#6, refer to the GUY-GRIP® Dead-end.
- (2) "Nominal Strand Size" indicates the strand which fits within the "Strand Diameter Range".
- (3) Reference Table 1 earlier in this section for acceptable fitting dimensions.
- (4) Cabled loop design is furnished as standard for all sizes.
- (5) Rated Holding Strengths (RHS) of the Big-Grip Dead-ends are listed for each strand and are expressed as a percent of the strand's Rated Breaking Strength (RBS).
- (6) Consult PLP for sizes and stranding not shown.



Big-Grip Dead-end

For use on: Galvanized Steel Structural Strand (Bridge)

Left-hand lay

Catalog Number	Big-Grip Made From:	Strand Construction	Nominal Strand Size (Inches)	BG Per Carton (Units)	BG Per Carton (Wt/ Lbs)	Approx Length (Inches)	Number of Individual Rods in Each Big-Grip	Color Code	Cables Published Rated Breaking Strength (Lbs)	Big-Grip Rated Holding Strength (Lbs)
BG-MS-6599	C-Coat Galvanized Steel	19W	1/2	10	39	52	5	Orange	30,000	30,000
BG-MS-7648	C-Coat Galvanized Steel	19W	9/16	10	49	55	5	Yellow	38,000	38,000
BG-MS-6446	B-Coat Galvanized Steel	19W	5/8	10	77	67	4	Black	48,000	48,000
BG-MS-1035	C-Coat Galvanized Steel	19W	11/16	5	54	74	5	Blue	58,000	58,000
BG-MS-3690	Aluminum Clad Steel Strand	19W	3/4	5	69	84	4	Orange	68,000	68,000
BG-MS-2759	Aluminum Clad Steel Strand	19W	13/16	5	73	85	5	Red	80,000	80,000
BG-MS-7346	Aluminum Clad Steel Strand	19W	7/8	3	58	94	5	Orange	92,000	92,000
BG-MS-7656	Aluminum Clad Steel Strand	19W	15/16	3	74	121	5	Blue	108,000	101,300

Lay Direction Guide
Examples of lay directions of strand or cable



LEFT-HAND LAY



RIGHT-HAND LAY

Right-hand lay

Catalog Number	Big-Grip Made From:	Strand Construction	Nominal Strand Size (Inches)	BG Per Carton (Units)	BG Per Carton (Wt/ Lbs)	Approx Length (Inches)	Number of Individual Rods in Each Big-Grip	Color Code	Cables Published Rated Breaking Strength (Lbs)	Big-Grip Rated Holding Strength (Lbs)
BG-MS-0717	C-Coat Galvanized Steel	19W	1/2	10	39	52	5	Orange	30,000	30,000
BG-MS-6604	C-Coat Galvanized Steel	19W	9/16	10	49	55	5	Blue	38,000	38,000
BG-MS-2617	B-Coat Galvanized Steel	19W	5/8	10	77	67	4	Black	48,000	48,000
BG-MS-6654	C-Coat Galvanized Steel	19W	11/16	5	54	74	5	Green	58,000	58,000
BG-MS-0704	Aluminum Clad Steel Strand	19W	3/4	5	69	84	4	Black	68,000	68,000
BG-MS-0721	Aluminum Clad Steel Strand	19W	13/16	5	73	85	5	Red	80,000	80,000
BG-MS-5548	Aluminum Clad Steel Strand	19W	7/8	3	58	94	5	Orange	92,000	92,000
BG-MS-7260	Aluminum Clad Steel Strand	19W	15/16	3	74	121	5	Blue	108,000	101,300

Big-Grip Dead-end

GALVANIZED STRAND

For use on: Extra High Strength
Siemens Martin High Strength
Utilities Grade

Used with AOA Guy Strain Insulators

AOA-35 AOA-65 AOA-120
AOA-50 AOA-85

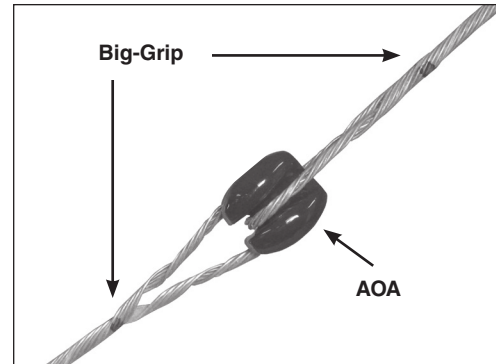

Catalog Number	Strand RTS (lbs)	Strand Size	Loop Diameter	Rated Loop Breaking Strength (lbs)
AOA-35		Seat Diameter = 2-7/16"		
BG-MS-5767	20,800	7/16"	2.875"	22,600
AOA-50		Seat Diameter = 2-11/16"		
BG-MS-5767	20,800	7/16"	2.875"	22,600
BG-MS-0751	26,900	1/2"	3.0"	29,900
BG-MS-4825	35,000	9/16"	3.5"	40,100
BG-MS-10754	42,400	5/8"	4.0"	45,300
AOA-65		Seat Diameter = 3"		
BG-MS-10417	42,400	5/8"	3.0"	45,300
BG-MS-9935	58,300	3/4"	4.25"	85,300
AOA-85		Seat Diameter = 4-3/16"		
BG-MS-9932	35,000	9/16"	4.25"	40,100
BG-MS-9935	58,300	3/4"	4.25"	85,300
BG-MS-7346	79,700	7/8"	4.25"	106,600
AOA-120		Seat Diameter = 4-5/8"		
BG-MS-10018	58,300	3/4"	4.5"	85,300
BG-MS-9936	79,700	7/8"	4.625"	106,600
BG-MS-14219	104,500 (19w)	1"	5"	106,600
	92,343 (37w)			95,900

Left-hand lay is standard.

Please visit our web site at www.preformed.com for additional literature.

Big-Grip Dead-end Application Procedure - SP2049

Big-Grip Dead-end Test Report - TR-634-E

Big-Grip Dead-ends are available for *PHILLYSTRAN® (SP2806).

Please consult PHILLYSTRAN for part numbers, availability and pricing.

Big-Grip Dead-end (PHILLYSTRAN) Test Report - TR-725-E.

**PHILLYSTRAN is a registered trademark of the Philadelphia Resins Corporation.*



End Sleeves

**For Use On:
C-Coat Galvanized Steel
Big-Grip Dead-ends**

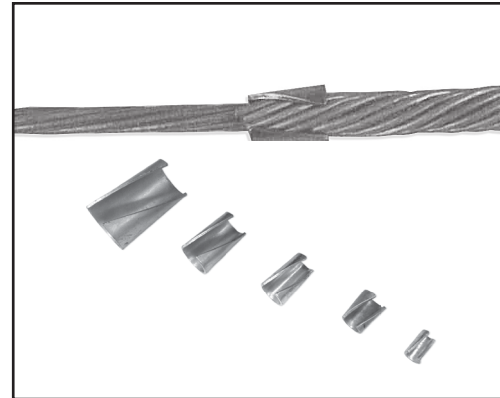

Galvanized Strand Size (inches)	Catalog Number C-Coat	End Sleeve Catalog Number
3/16	BG-2142	GC-65303
1/4	BG-2144	GC-65136
5/16	BG-2146	GC-65128
3/8	BG-2147	GC-65264
7/16	BG-2148	GC-65265
1/2	BG-2115	GC-65266
9/16	BG-2116	GC-65267
5/8	BG-2111	GC-65268
11/16 or 3/4	BG-2112	GC-65269
13/16 or 7/8	*BG-MS-7023	GC-65270
15/16 or 1	*BG-MS-7047	GC-65271

*Manufactured from aluminum clad steel strand