

# LCD-2537

## Multi-Configurable Mid-Size Flat Panel Articulating Mount

### Product Features:

Can be configured as a single arm, double arm or near flush mount w/ the parts provided

Holds most 25" – 32" flat panels

Accommodates panels with 75, 100, 200 and 100 x 200 mm VESA standards

Adjustable -5° to +20° tilt

Rotates 240° at the elbow joint (Double Arm configuration)

Rotates 240° at the panel / Rotates 160° at the wall

Feed through wall plate with decorative cover

Includes clip based cable management system

Load capacity - 50 lbs / Silver powder coat finish

Also available in black finish (LCD-2537B)

### Product Specifications:

*(for Architects & Engineers)*

The articulating wall mount for the flat panel display shall be the Video Mount Products (VMP) model LCD-2537. The mount shall be designed to attach to a single stud of other suitable support surface. The mount shall be constructed primarily of tubular steel and shall incorporate nylon nuts and arc welds. The mount shall be a universal style capable of mounting to all 25" to 32" LCD monitors that incorporate 75mm, 100mm, 100x200 mm, and 200mm standard mounting hole patterns and not necessarily be model specific. The mount shall include one mounting plate that meets VESA 75 and 100 and one mounting plate which meets VESA 100x200 and 200. The mount shall include a cable management system. The mount shall be multi-configurable and capable of being assembled as a double arm articulating, single arm, or near flush mount with parts provided. The mount must allow for adjustable tilt from -5° to 30°. The load capacity shall be 50 lbs.

### Video Mount Products

345 Log Canoe Circle

Stevensville, MD 21666

Toll Free: 877.281.2169

Telephone: 410.643.6390

Facsimile: 410.643.6615

[www.videomount.com](http://www.videomount.com)

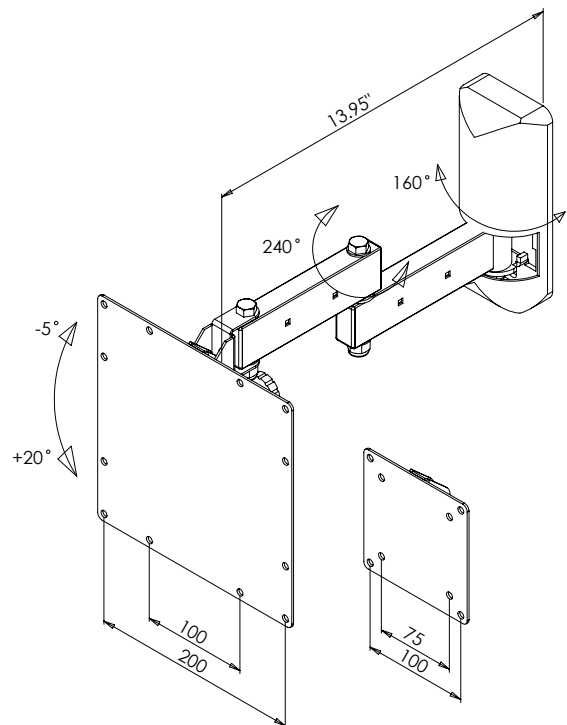
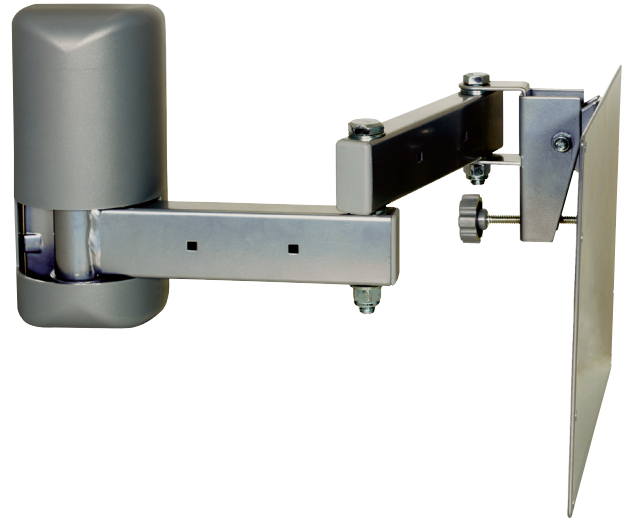

**VMP**  
VIDEO MOUNT PRODUCTS