

# LCD-WM2

*dual LCD monitor wall mount*

## Product Features:

allows attachment of 2 LCD-1 mounts  
(sold separately)

arm extends 11" from wall

load capacity 50 lbs.

silver powder coat finish

## Product Specifications:

*(for Architects & Engineers)*

The adaptor which will allow two single stud wall mounted LCD displays shall be the Video Mount Products (VMP) model LCD-WM2. The adaptor shall be used with two LCD-1s to mount LCD displays to a single stud or other suitable support surface. The adaptor shall be constructed primarily of tubular steel and shall incorporate arc welds. The load capacity of the adaptor shall be 50 lbs.

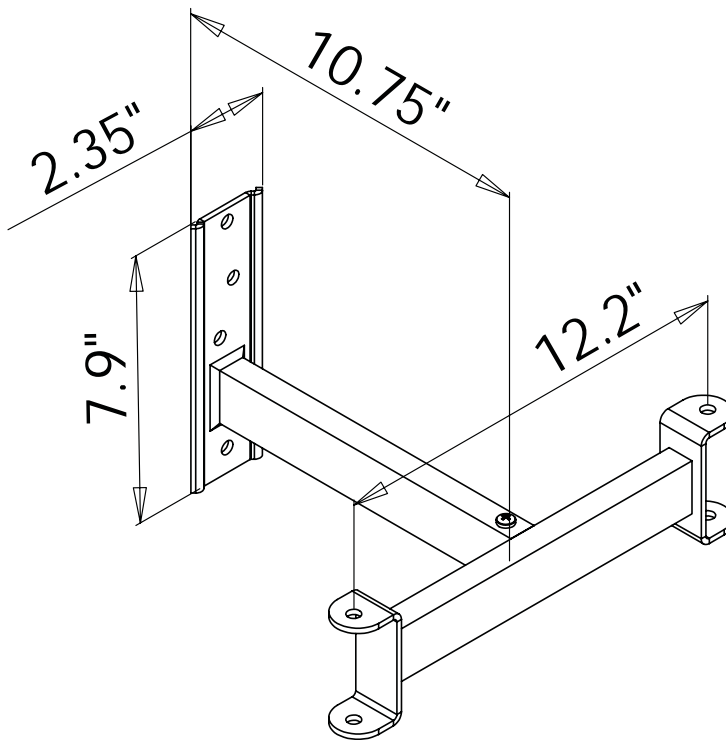

## Video Mount Products

325 Log Canoe Circle

Stevensville, MD 21666

Phone: 410.643.6390

Fax: 410.643.6615

[www.videomount.com](http://www.videomount.com)

