

WMP

VIDEO MOUNT PRODUCTS

Instruction Sheet For:
LCD-WM2

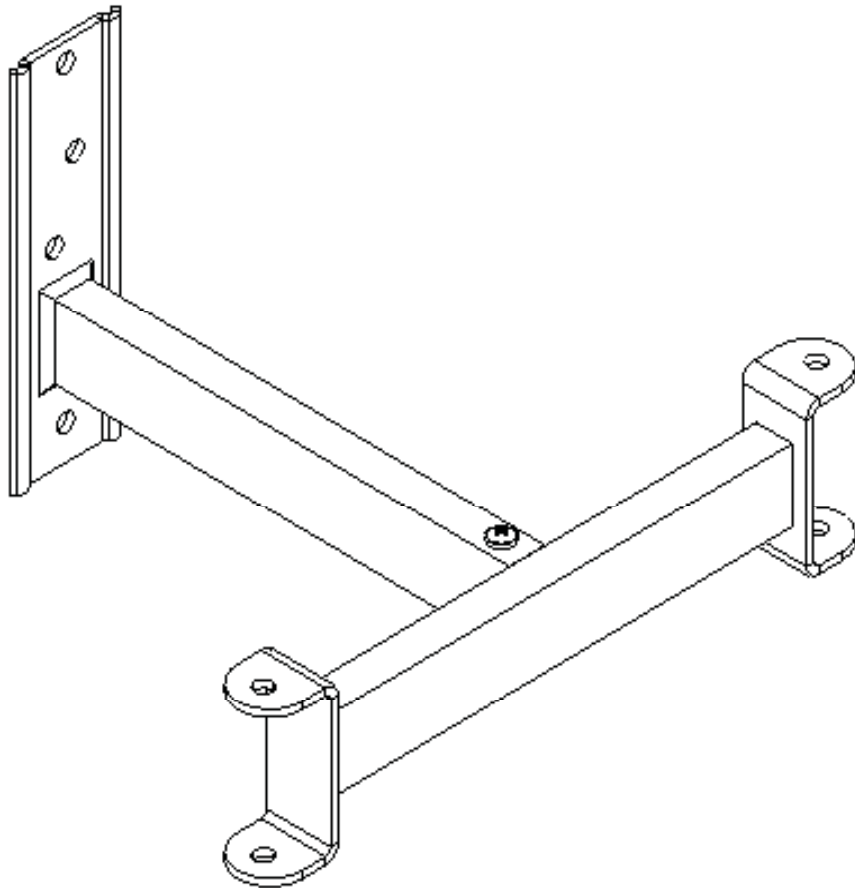

For more information, please contact us at:
325 Log Canoe Circle, Stevensville, Maryland 21666
(T) 410.643.6390 / (F) 410.643.6615
www.videomount.com

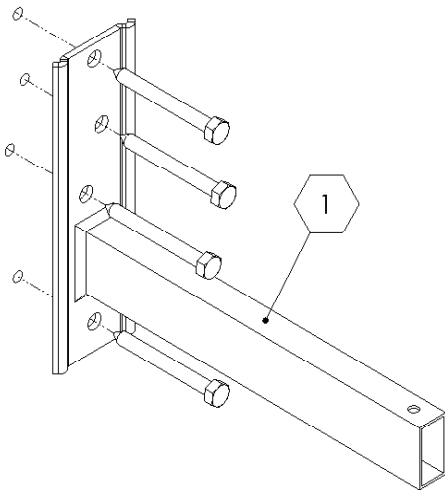

Step 2: Attaching the wall plate to the wall
(Lag screws are not included)

Step 1

Before starting, lay out all parts to your mount and match them to the parts list provided. Verify that you have all your parts before attempting to assemble the mount. **Note: The LCD-WM2 and LCD-1 combo was designed to mount two of the same TV or TVs of similar size and weight. It is not designed to have two significantly different TVs mounted. Also note that LCD-1 part numbers have circles around their numbers and LCD-WM2 has hexagons around its part numbers.**

Step 2

Mark the wall or desired mounting surface in preparation of installation of the wall plate **1** LCD-WM2. Pre-drill, if necessary, and mount the wall plate **1** LCD-WM2 to the desired mounting surface. **Warning: Please verify that your mounting surface will support the combined weight of your mount, mounting hardware, and monitor. Also verify that the mounting surface is safe to drill through. If in doubt, please contact a professional installer.**

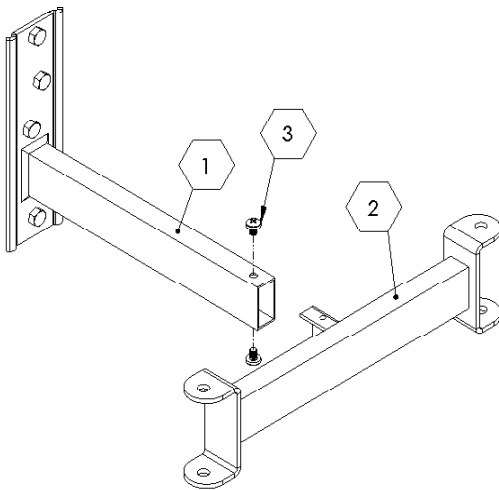

Step 3

Attach the connector support **2** LCD-WM2 to the wall plate **1** LCD-WM2 using the M6 screws **3** LCD-WM2.



Step 3: Attaching the connector support to the wall plate

Key:

	LCD-1
	LCD-WM2

WMP
VIDEO MOUNT PRODUCTS

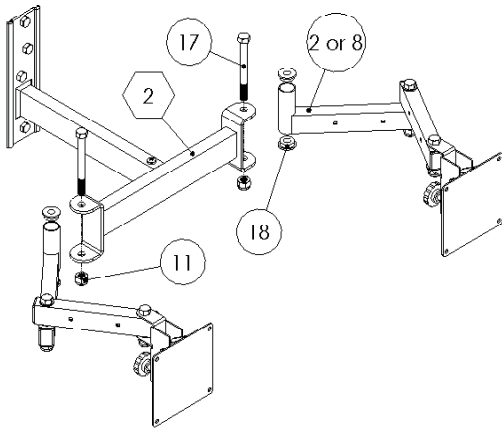

Step 4: Attaching the LCD-1s to the connector support

Step 4

For this step it is assumed that the LCD-1s are assumed in the specific configuration (near flush, single arm, or double arm) desired with the pivot bracket (4) LCD-1 and mounting plate (5) or (6) LCD-1 attached. If not please take the time to do so now. Insert the plastic flanges (18) LCD-1 into the desired force arms (2) or (8) LCD-1. Attach the desired force arms (2) or (8) LCD-1 to the connector support (2) LCD-WM2 using the 3/8" screw (17) LCD-1 and nylon nut (11) LCD-1.

Step 5

Attach the TVs to the mounting plates (5) or (6) LCD-1 using the M4 (19) LCD-1 or M5 (20) LCD-1 screws as appropriate. **Please verify that all nuts and screws are tight.**

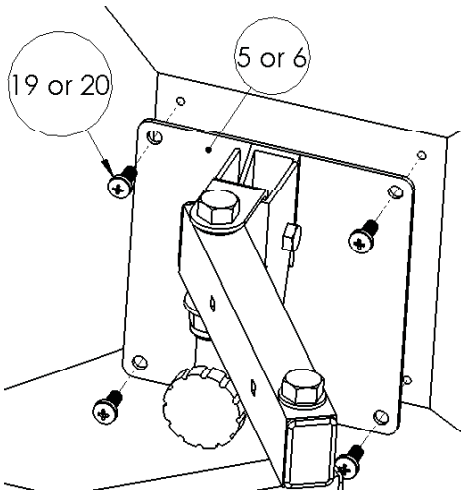

Step 5: Attaching the TVs to the LCD-1s

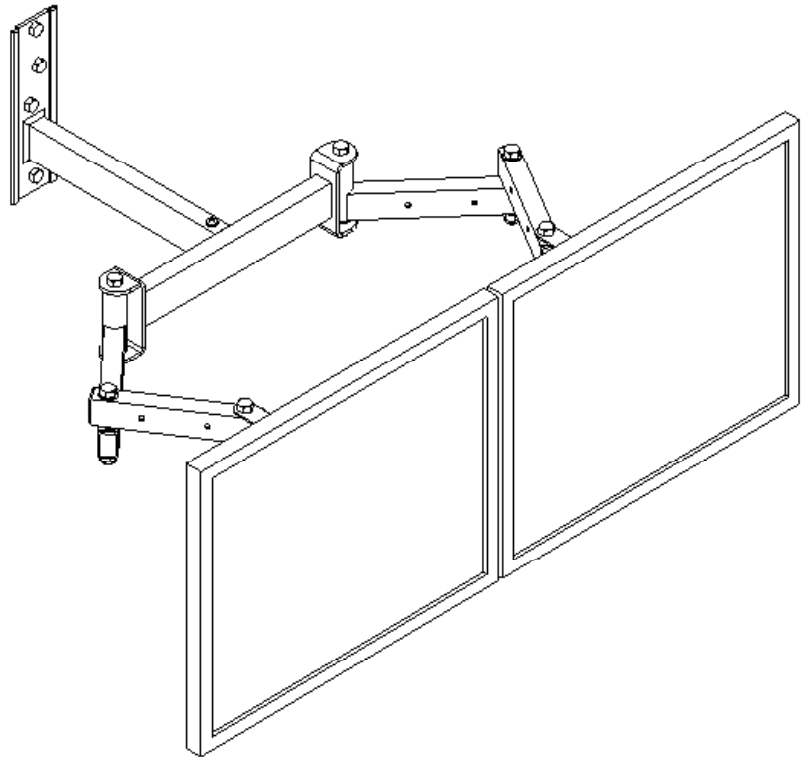

Enjoy Your Mount!

WMP
VIDEO MOUNT PRODUCTS

WARNING: The installer of these products must verify that the mounting surface, ceiling or wall, will safely support the combined weight of all attached equipment and hardware. Video Mount products will not be held liable for the improper use or installation of its products.