

PDS-LWA

Large Flat Panel Flush Mount With Tilt

Product Features:

Holds most 42" – 63" flat panels

Maximum flat panel hole pattern – 950mm x 530mm

Rotates 45° and has adjustable -5° to +15° tilt

Depth 4.3" (arms fully collapsed)

Depth 24" (arms fully extended)

Includes cable management covers

Load capacity - 180 lbs

Silver powder coat finish

Also available in black (PDS-LWAB)

Product Specifications:

(for Architects & Engineers)

The articulating wall mount for the large flat panel display shall be the Video Mount Products (VMP) PDS-LWA. The mount shall be designed to attach to 2 studs up to 24" apart or other suitable support surface. The mount shall be constructed primarily of formed steel and aluminum and shall incorporate arc welds. The mount shall be a universal style mount capable of adjusting to the dimensions of a variety of popular 42" to 63" flat panel displays and not necessarily be model specific. The adjustable mounting rails shall be capable of accommodating a maximum hole pattern of 950 mm wide and 530 mm tall. The mount shall be capable of tilting from -5° to +15°. The load capacity shall be 180 lbs.

Video Mount Products

345 Log Canoe Circle

Stevensville, MD 21666

Toll Free: 877.281.2169

Telephone: 410.643.6390

Facsimile: 410.643.6615

www.videomount.com

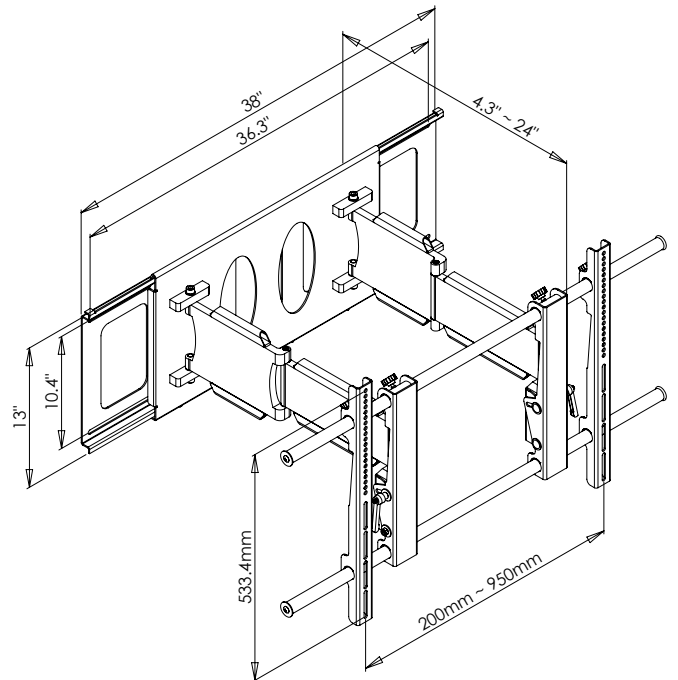

VMP
VIDEO MOUNT PRODUCTS