

# **WMP**

VIDEO MOUNT PRODUCTS

*Instruction Sheet For:*

## **VH-001 & VH-001S**

---

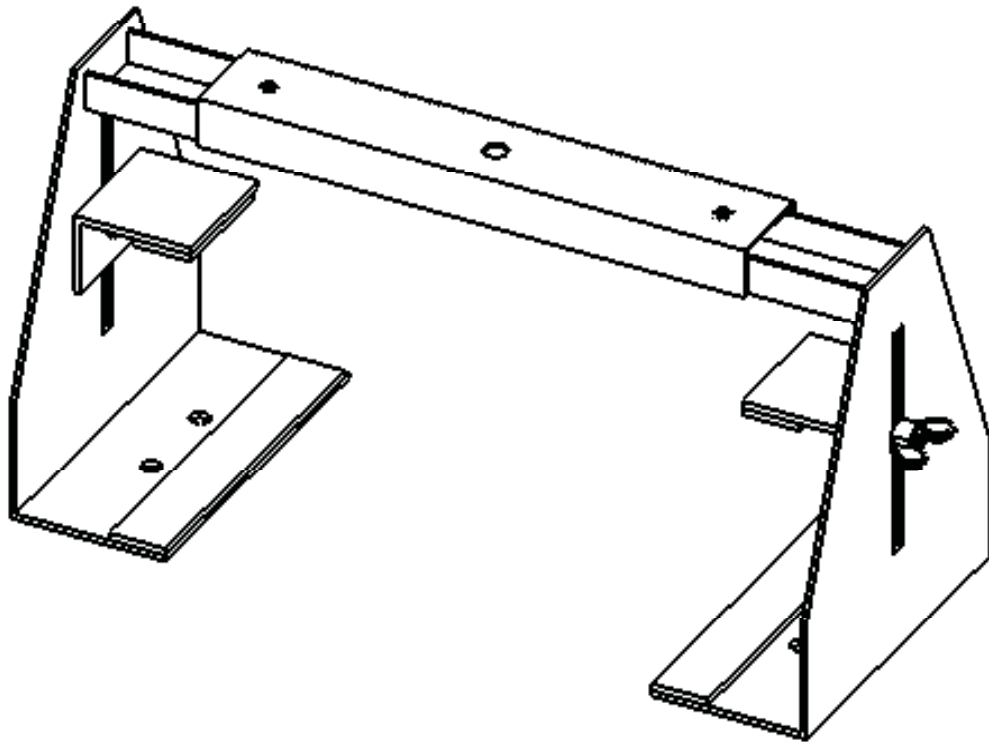

---

*For more information, please contact us at:  
325 Log Canoe Circle, Stevensville, Maryland 21666  
(T) 410.643.6390 / (F) 410.643.6615  
[www.videomount.com](http://www.videomount.com)*

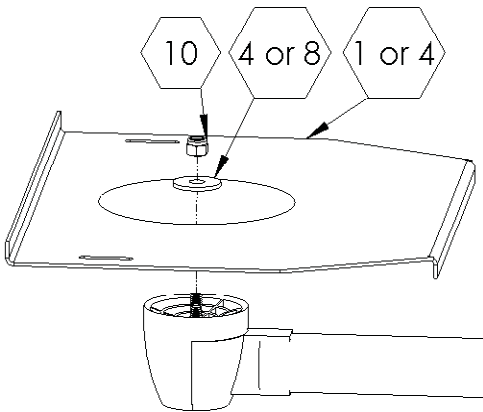

Step 3: Removing the platform from the W-13/C-13

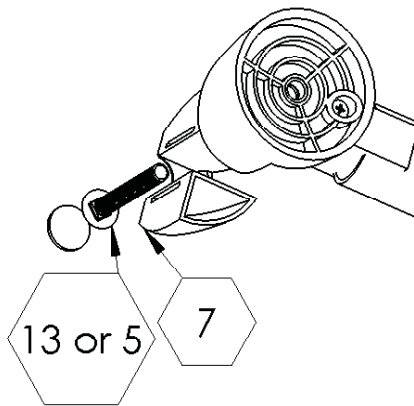

Step 4: Removing the plastic connector and swivel

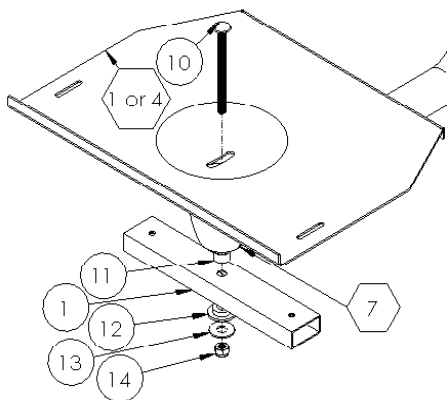

Step 5: Attaching the force arm

### Step 1

Before starting lay out all parts to your mount and match them to the parts list provided. Verify that you have all your parts necessary for the primary mount you are attaching to before attempting to assemble the mount. Note: VH-001 part numbers are in circles and non-VH-001 part numbers are in hexagons.

### Step 2

To determine which steps to follow, first determine which mount you are trying to attach to the VH-001. **If you are trying to connect the VH-001 to a W-13 or a C-13** proceed to step 3. **If you are trying to connect the VH-001 to a C-20, C-27, W-20, or W-27** proceed to step 6. **If you are trying to connect the VH-001 to a new style VMP014/024, VMP036/038, VMP042/044, or VMP046/048** proceed to step 9. **If you are trying to connect the VH-001 to a VMP001, VMP003, or VMP006** proceed to step 11. **Note: Instructions assume that you have already assembled the primary mount.**

VH-001 to W13 or C13

### Step 3

First remove the TV from the mount. Next remove the platform (1) W-13 or (4) C-13 by removing the nylon nut and washer (10) and (4) W-13 or (10) and (8) C-13.

### Step 4

Remove the plastic swivel (7) W-13 and C-13. Snap off the plastic circle on the bottom of the plastic swivel (7) W-13 and C-13 and remove the 2.5" long screw (13) W-13 or (5) C-13.

### Step 5

Attach the VH-001 force arm (1) VH-001 to the bottom of the plastic swivel by inserting the long screw (10) VH-001 through the platform (1) W-13 or (4) C-13 through the plastic swivel (7) VH-001 and the spacer (11) VH-001. Continue by inserting the long screw through the VH-001 force arm (1) VH-001 and through the plug (12) VH-001, washer (13) VH-001, and then attach and tighten the nylon nut (14) VH-001. **Once this is completed please skip to step 14.**

Key:

○	VH-001
⬡	Non VH-001 Parts

**VMP**  
VIDEO MOUNT PRODUCTS

VH-001 to W20, W27, C20, or C27

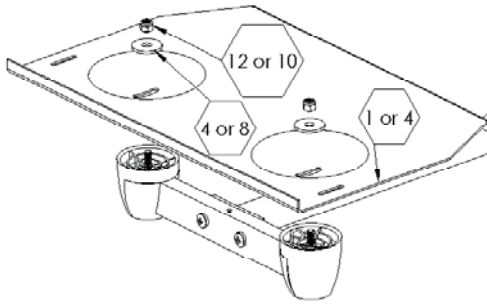

Step 6: Removing the platform

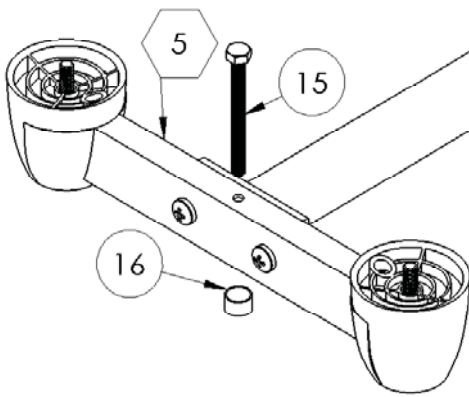

Step 7: Inserting the connector screw

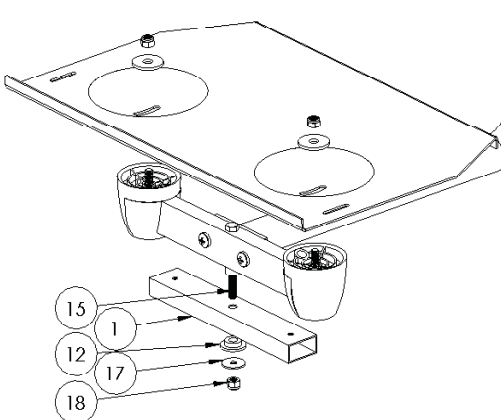

Step 8: Attaching the VH-001 force arm

### Step 6

First remove the platform **1** W20 & W27 or **4** C20 & C27 by removing the washers and nylon nuts **4** and **12** W20 & W27 or **8** and **10** C20 & C27 from the indentations in the platform.

### Step 7

Insert the M6 screw **15** VH-001 through the top of the force arm **5** W20, W27, C20 & C27 and place the spacer **16** VH-001 around the screw underneath the force arm **5** for W20, W27, C20 & C27.

### Step 8

Connect the VH-001 force arm **1** VH-001 by inserting the M6 screw **15** VH-001 through the force arm and securing with a plug, washer, and nylon nut **12**, **17**, and **18** VH-001 and reattach the platform by reversing step 6. **Once this is completed please skip to step 14.**

VH-001 to VMP014/024, VMP036/038, VMP042/044 or VMP046/048

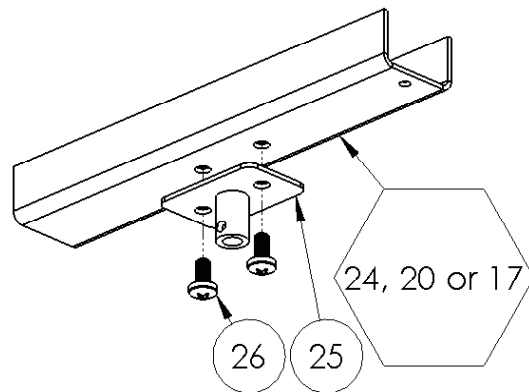

### Step 9

Attach the connector **25** VH-001 to the lower force arm **24** VMP014/024, **20** VMP036/038, and **17** VMP042/044 and VMP046/048 using M6 screws **26** VH-001.



Step 9: Attaching the connector

Key:

	VH-001
	Non VH-001 Parts



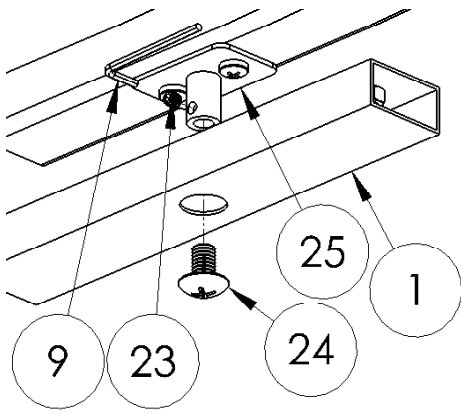

Step 10 : Attaching the force arm

### Step 10

Attach the VH-001 force arm (1) *VH-001* to the connector (25) *VH-001* using the 3/8" screw (24) *VH-001* and washer (13) *VH-001* in between the connector and the force arm. Insert a brake screw (23) *VH-001* into the connector using the M3 Allen key (9) *VH-001* to tighten it down onto the 3/8" screw. **Once this is completed please skip to step 14.**

*VH-001 to VMP001, VMP003, or VMP006*

### Step 11

First remove the nylon nut (12) *VMP001*, (14) *VMP003*, and (11) *VMP006* from the bottom of the fixed bracket (4) *VMP001* and *VMP003* or the 3/8" screw (9) *VMP006*.

### Step 12

Replace the nylon nut with the long nut (27) *VH-001* and tighten the brake screw (23) *VH-001* onto the fixed bracket (4) *VMP001* and *VMP003* or the 3/8" screw (9) *VMP006* using the M3 Allen Key (9) *VH-001*.

### Step 13

Attach the VH-001 force arm (1) *VH-001* by inserting a washer (13) *VH-001* between the nut (27) *VH-001* and force arm and then using the 3/8" screw (24) *VH-001* attach the force arm to the nut. Once the 3/8" screw (24) *VH-001* is securely tightened, use a brake screw (23) *VH-001* to secure the 3/8" screw in the nut. **Once this is completed please proceed to step 14.**

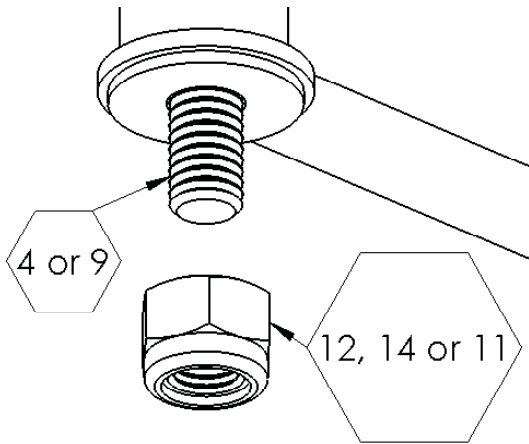

Step 11 : Removing the nylon nut

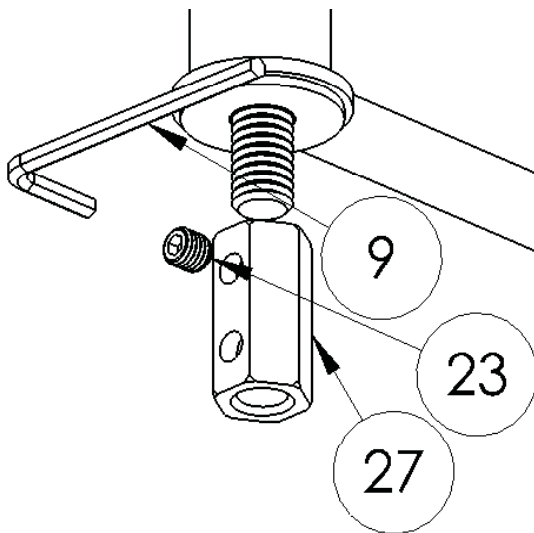

Step 12: Attaching the long nut

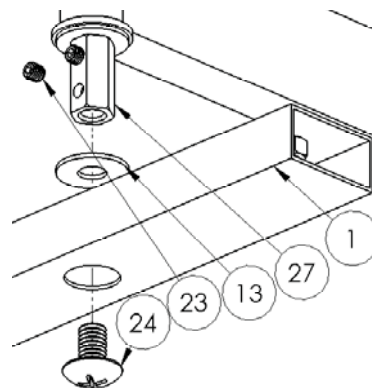

Step 13 : Attaching the force arm

### Key:

○	<i>VH-001</i>
⬡	<i>Non VH-001 Parts</i>

**VMP**  
VIDEO MOUNT PRODUCTS

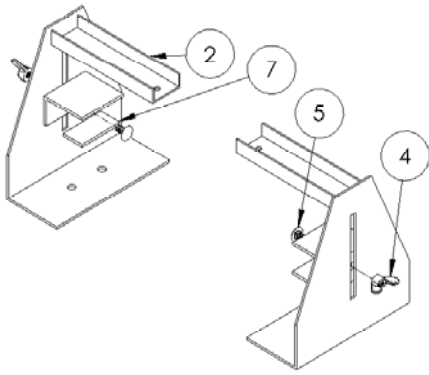

Step 14: Assembling the extension holders

### Step 14

Now that the VH-001 force arm (1) VH-001 is attached, it is time to assemble the rest of the VH-001. First attach the non-skid padding (7) VH-001 to the adjustable stopper (3) VH-001. Next attach the adjustable stoppers (3) VH-001 to the extension holder (2) VH-001 using the butterfly nuts and 1/4" - 20UNC screws (5) and (4) VH-001.

### Step 15

Take the Velcro (6) VH-001 and apply it to the equipment you are going to place in the VH-001 and on the extension holders (2) VH-001. You should apply the Velcro to the bottom left and right sides of your equipment along the edges.

### Step 16

Insert the extension holders (2) VH-001 into the force arm (1) VH-001. Slide the desired equipment in between the adjustable stoppers and both extension holders (3) and (2) VH-001. Secure the position of the extension holders by tightening down brake screws (8) VH-001 into the force arm while making sure the equipment is centered in the bracket. Lastly, slide the adjustable stoppers down onto the top of the equipment and tighten.

*Please verify that all nuts and screws are securely tightened.*

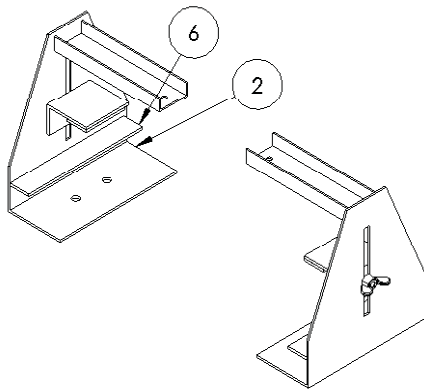
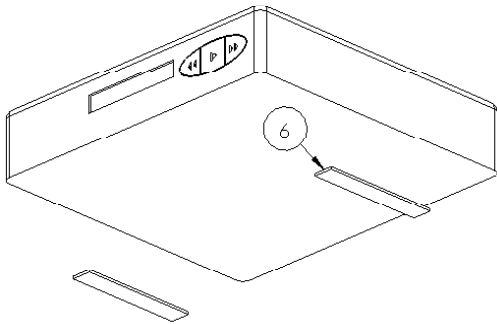

Step 15 : Applying Velcro

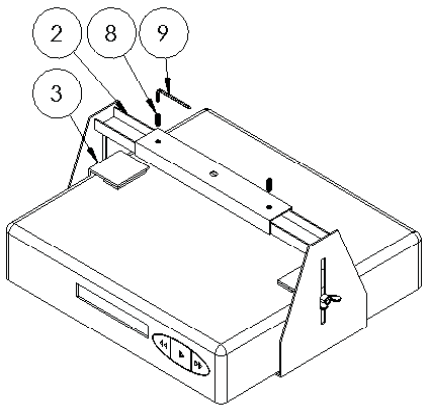

Step 16 : Securing the equipment in the VH-001 (VH-001 is shown without being attached to a mount for clarity)

## Enjoy Your Mount!

**WARNING:** The installer of these products must verify that the mounting surface, ceiling or wall, will safely support the combined weight of all attached equipment and hardware. Video Mount Products will not be held liable for the improper use or installation of its products.